

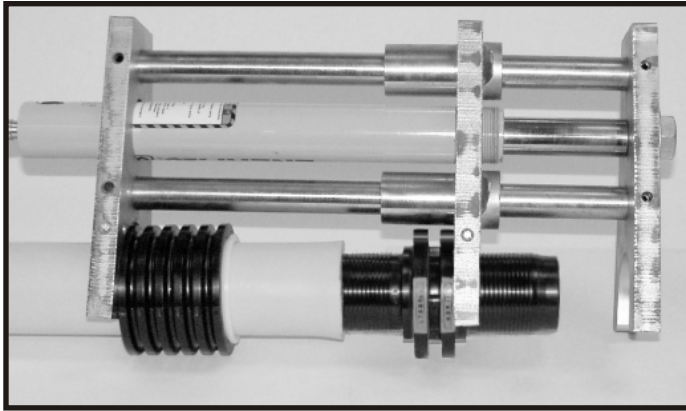

R. W. Lyall & Company, Inc.



LAP100 **LYCO® Large Hydraulic Tool** Installation Procedure For **LYCOFIT® 1-1/4" IPS, 1-1/2" IPS, 2" IPS Fittings**

IMPORTANT:

1. **DO NOT** apply lubricants to fitting's spigot or sleeves.
 2. Squeeze off PE pipe when using coupling for repair OR line extension to insure flow is stopped.
 3. The **LAP100** tool is intended for installing **LYCOFIT®** couplings and fittings only.
 4. **LYCOFIT®** couplings are designed to be installed on O.D. controlled Polythene pipe only. Examine pipe and coupling labels and install coupling and Fittings only to pipe with correct size and wall thickness/SDR dimensions.
 5. Pressure test each fitting after installation to comply with minimum pipeline test requirements as specified in D.O.T. Title 49, Part 192, Sub Part J-Test Requirements.
- A.** The LAP100 Large Hydraulic Tool is for installing **LYCOFIT®** 1-1/4" IPS, 1-1/2" IPS, 2" IPS sized Couplings and Fittings, Field assembled transitions, and Lyall Risers with optional **LYCOFIT®** connections.
- B.** This manual covers installation of **LYCOFIT®** fittings using the **LAP-100 Tool with LycoRing** for standard couplings. For installing **LYCOFIT®** 1-1/4 IPS and 2 IPS Repair couplings, please reference the instructions specific to the product:
For 1-1/4 IPS Repair Coupling installation, refer to Lyall Doc# LIT-LCINST-05
For 2 IPS Repair Coupling installation, refer to Lyall Doc# LIT-LCINST-04
- D.** The LAP100 tool requires a hydraulic source to operate. The AHP100 (ENERPAC™ P142) is available through Lyall as a hand pump source for operating the LAP100 tool. Other hydraulic power sources with a minimum of 10,000 psi may be used. Before starting pipe connection, install hose from hydraulic source to the LAP100's hydraulic piston connector.

CUSTOMER SERVICE: 1 (800) 535-9255

Doc# LIT-LAP100INST
rev. 2C

Installing Double Ended Couplings

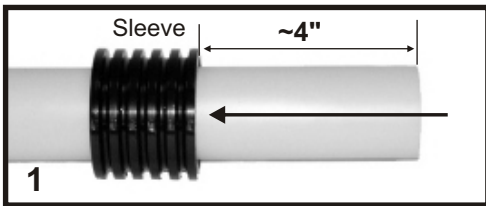

Step 1 Completion Sleeve Insertion

A) With the PE pipe reasonably clean, slide the sleeve onto PE pipe exposing approx. 4" of the tubing.

Note: Completion sleeves are non-directional and can be slid onto the pipe via either end.

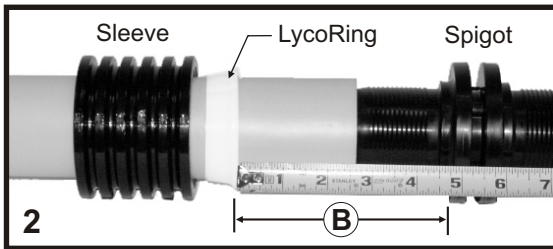

Step 2 LycoRing Placement

A) Slide the LycoRing (small diameter first) onto the PE pipe.

Note: The LycoRing may be damaged if ring is pushed over pipe.

B) Push spigot end into end of PE pipe and position LycoRing to 4-¾" from nearest spigot flange.

LAP-100 TOOL INSTALLATION PROCEDURE USING LycoRing® (Disposable pipe gripping ring)

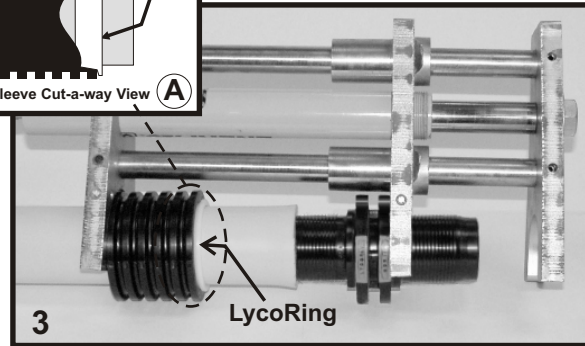
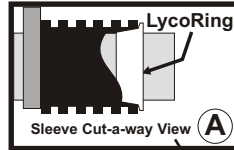
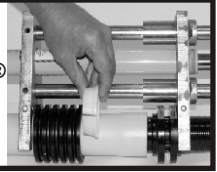

Step 3 Inserting Fitting into Tool

A) Slide the sleeve over the LycoRing so the ring starts to grip pipe (see cut-a-way illustration "A").

B) Position the PE pipe & completion sleeve into the LAP and use pump to bring the tool's moving jaw into place as shown in Fig. 3).

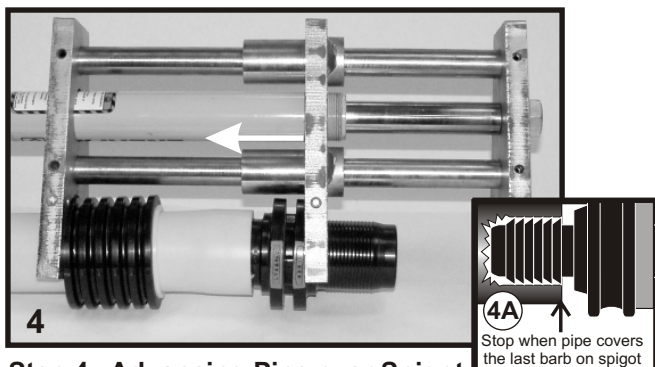

Step 4 Advancing Pipe over Spigot

A) Operate hydraulic pump to advance pipe over spigot until pipe covers the last barb on spigot (See Fig 4A).

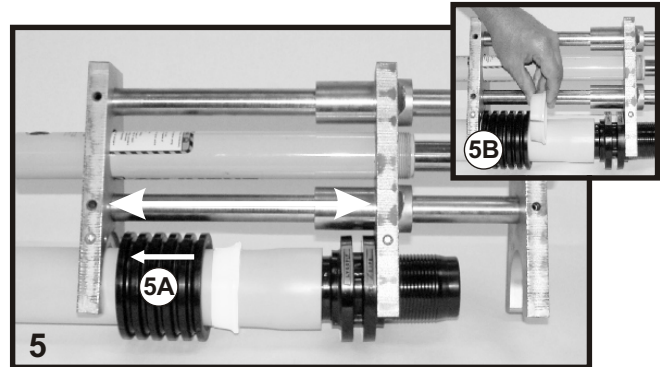

Step 5 Removing LycoRing.

A) Release hydraulic pressure and let tool jaw open enough to pull sleeve back to expose the LycoRing.

B) Remove the LycoRing by pushing the slotted side of the ring apart and away from the pipe.

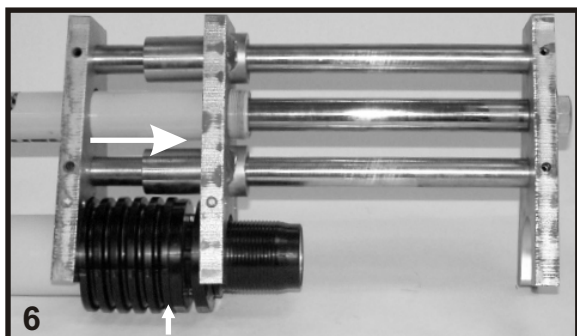

Step 6 Advancing Sleeve over Spigot

A) Operate pump to advance the completion sleeve over the PE pipe and spigot. Stop sleeve advancement when the sleeve is fully inserted over the spigot (as shown in Fig. 6).

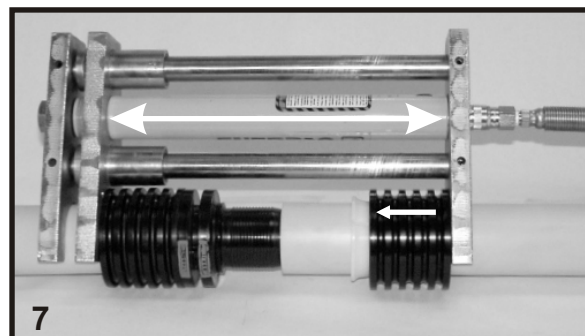

Step 6 Complete Fitting

A) To assemble the opposite side of the coupling, open tool fully and repeat steps 1 through 6 above, but with tool direction flipped in opposite direction.

Step 7 Test Completed Fitting (For gas fittings)

Pressure test each fitting after installation to comply with the minimum pipeline test requirements as specified in **D.O.T. Title 49, Part 192, Sub Part J-Test Requirements.**



READ INSTRUCTIONS BEFORE INSTALLING

LYCOFIT® 1-1/4" IPS Repair Coupling

Using Lap-100 Large Hydraulic Tool

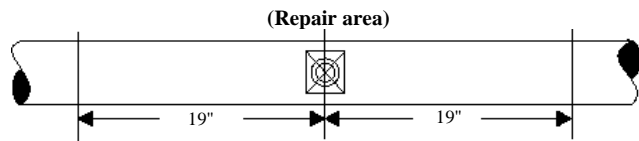

NOTE: LYCOFIT® Repair Clearance Requirements
The dimensions above are clearance requirements to facilitate the LYCOFIT® repair Process.

IMPORTANT NOTES:

- 1) **DO NOT** apply lubricants to LYCOFIT® spigot or sleeves.
- 2) LYCOFIT® couplings to be installed on O. D. controlled PE natural / LP gas pipe only. Examine pipe and coupling labels and install couplings only to pipe with correct size and wall thickness / SDR dimensions.
- 3) The measurements within this procedure are for **1-1/4" IPS pipe repairs ONLY**. The measurements shown differ for other sizes. Please refer to the proper LYCOFIT® Repair Coupling procedure when repairing other pipe sizes.

Step 1

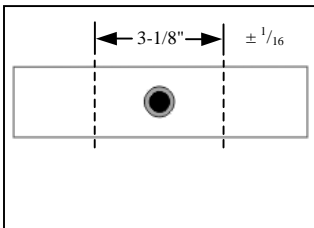

1. Shut off gas flow to damaged gas line.
Mark and cut out damaged PE pipe at the distance of 3-1/8 inches $\pm 1/16$.
Note: Cuts must be square.

Step 2

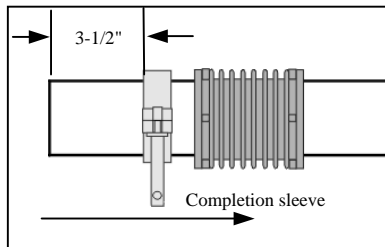

2. Slide completion sleeve onto PE pipe.
Mark PE pipe at 3-1/2".
Attach 1-1/4" clamp, at edge of marked distance.
Tighten clamp securely.

Step 3

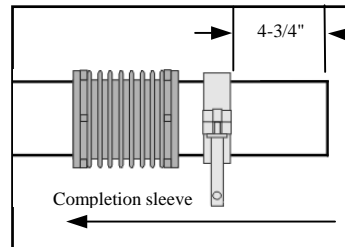

3. Slide completion sleeve onto other end of PE pipe.
Mark PE pipe at 4-3/4".
Attach 1-1/4" clamp, at edge of marked distance.
Tighten clamp securely.

Step 4

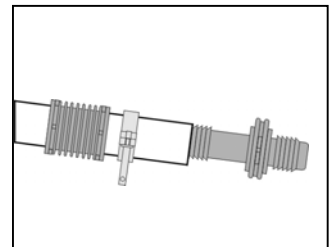

4. Deflect pipe towards the operator and insert long end of repair coupling spigot into end of the PE pipe.

Step 5

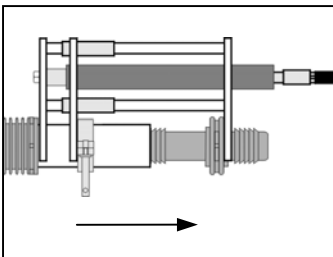

5. Open tool to its full open position.
Position tool as shown in illustration.
Close valve and start operating hand pump.

Step 6

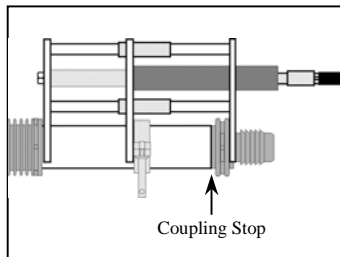

6. Bring the end of the of the PE flush with the coupling stop.
DO NOT FORCE CLAMP AGAINST COUPLING STOP.
Release pump pressure and remove tool.

Step 7

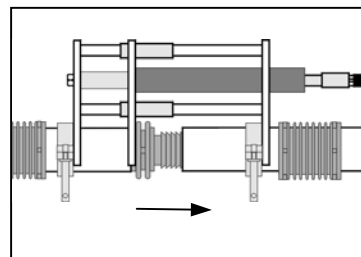

7. Insert short end of the coupling spigot into pipe.
Reposition tool as shown and start operation of hand pump.

Step 8

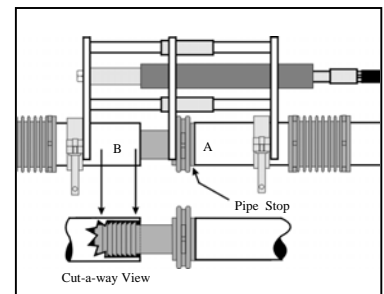

8. Stop operation of the hand pump when the short end of the spigot is fully inserted (A).
Check that the pipe overlaps spigot barbs as shown (B).

Step 9

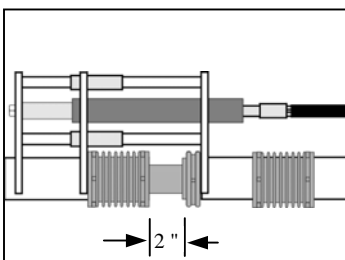

9. Slide completion sleeve toward coupling on the long end.
Complete using tool, stopping when there is a 2" gap between the sleeve and coupling as shown.

Step 10

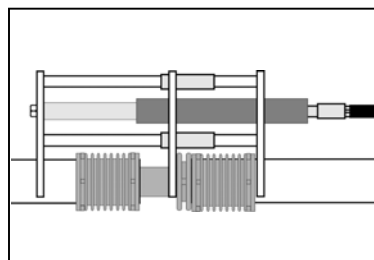

10. Slide completion sleeve toward coupling on the short end.
Complete using tool, stopping when completion sleeve is against coupling.

Step 11

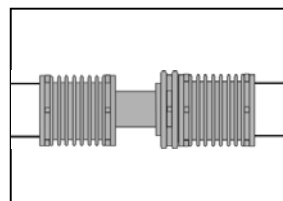

11. Remove tool. Coupling is complete.
Pressure test each fitting after installation to comply with minimum pipeline test requirements as specified in D.O.T. Title 49 Part 192, Sub Part J-Test Requirements.

Note: Prior to removing clamps, ensure clamps have not moved from their original marked locations.

Remove tool and pipe clamps.

This Lyall Product:
Conforms to Code of Federal Regulations Title 49 Part 192
ASTM D2513 Category 1 CD

U.S. Patent No. 4635972

R.W. Lyall & Company, Inc. 2665 Research Drive Corona, Ca. 92882-6918 • Customer Service (951) 270-1500 • Web-site www.rwlyall.com

RWL Logo, LYCOFIT are registered trademarks of R.W. Lyall & Company, Inc.

Doc#: LIT-LCINST-05
rev. 6B (090804)

© 2004 R. W. Lyall & Company, Inc.



READ INSTRUCTIONS BEFORE INSTALLING

LYCOFIT® 2" IPS Repair Coupling

Using Lap-100 Large Hydraulic Tool with "Pull-Back" Clamp

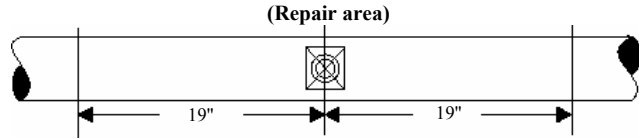

NOTE: LYCOFIT® Repair Clearance Requirements
The dimensions above are clearance requirements to facilitate the LYCOFIT® repair Process.

IMPORTANT NOTES:

- 1) **DO NOT** apply lubricants to LYCOFIT® spigot or sleeves.
- 2) LYCOFIT® couplings to be installed on O.D. controlled PE natural / LP gas pipe only. Examine pipe and coupling labels and install couplings only to pipe with correct size and wall thickness / SDR dimensions.
- 3) The measurements within this procedure are for **2" IPS pipe repairs ONLY**. The measurements shown differ for other sizes. Please refer to the proper LYCOFIT® Repair Coupling procedure when repairing other pipe sizes.

Step 1

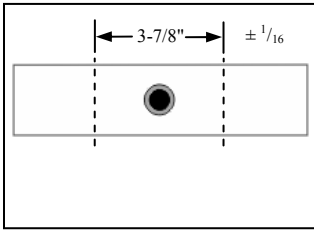

1. Shut off gas flow to damaged gas line.
Mark and cut out damaged PE pipe at the distance of 3-7/8 inches.

Note: Cuts must be square.

Step 2

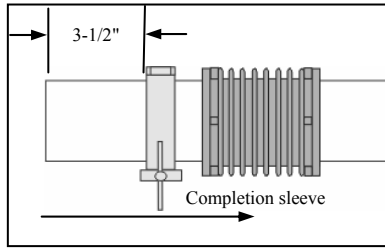

2. Slide completion sleeve onto PE pipe.
Mark PE pipe at 3-1/2".
Attach small pipe clamp on to pipe PE to edge of marked distance.

Tighten clamp securely.

Step 3

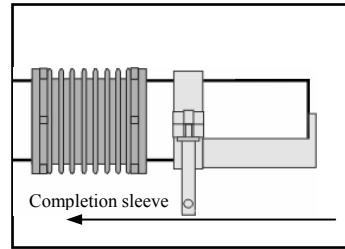

3. Slide completion sleeve onto other end of PE pipe.

Attach 2" large "pull-back" clamp, ensure clamp edge is butted up against the end of pipe.

Tighten clamp securely.

Step 4

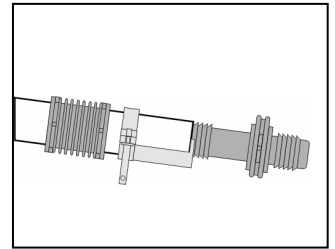

4. Deflect pipe towards the operator and insert long end of repair coupling spigot into end of the PE pipe.

Step 5

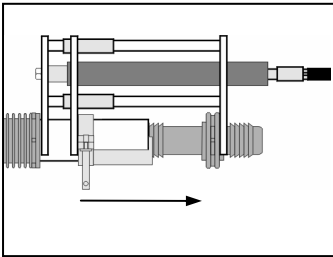

5. Open tool to its full open position.
Position tool as shown in illustration.
Close valve and start operating hand pump.

Step 6

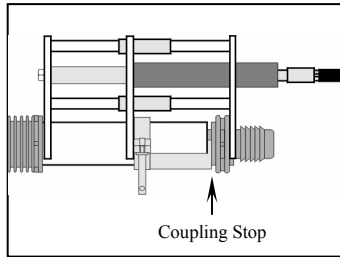

6. Bring the end of the "pull-back" clamp up flush with coupling stop.
DO NOT FORCE CLAMP AGAINST COUPLING STOP.
Release pump pressure and remove tool.

Step 7

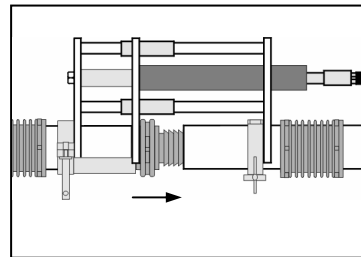

7. Insert short end of the coupling spigot into pipe.
Reposition tool as shown and start operation of hand pump.

Step 8

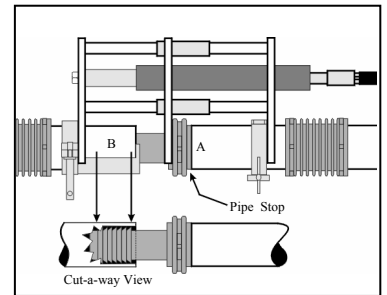

8. Stop operation of the hand pump when the short end of the spigot is fully inserted (A). Check that the pipe overlaps spigot barbs as shown (B).

Note: Prior to removing clamps, ensure clamps have not moved from their original marked locations.

Remove tool and pipe clamps.

Step 9

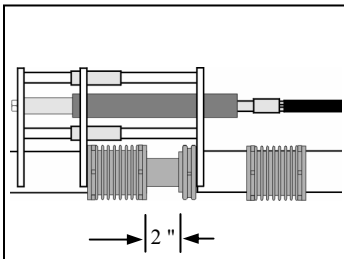

9. Slide completion sleeve toward coupling on the long end.
Complete using tool, stopping when there is a 2" gap between the sleeve and coupling as shown.

Step 10

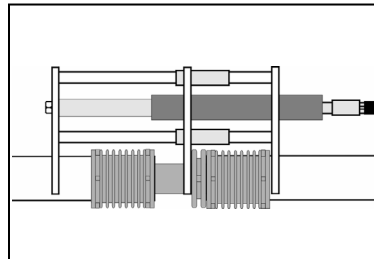

10. Slide completion sleeve toward coupling on the short end.
Complete using tool, stopping when completion sleeve is against coupling.

Step 11

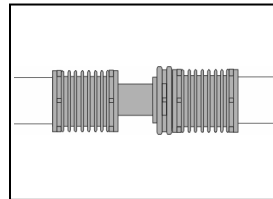

11. Remove tool. Coupling is complete.
Pressure test each fitting after installation to comply with minimum pipeline test requirements as specified in D.O.T. Title 49 Part 192, Sub Part J-Test Requirements.

This Lyall Product:
Conforms to Code of Federal Regulations Title 49 Part 192
ASTM D2513 Category 1 CD

U.S. Patent No. 4635972