

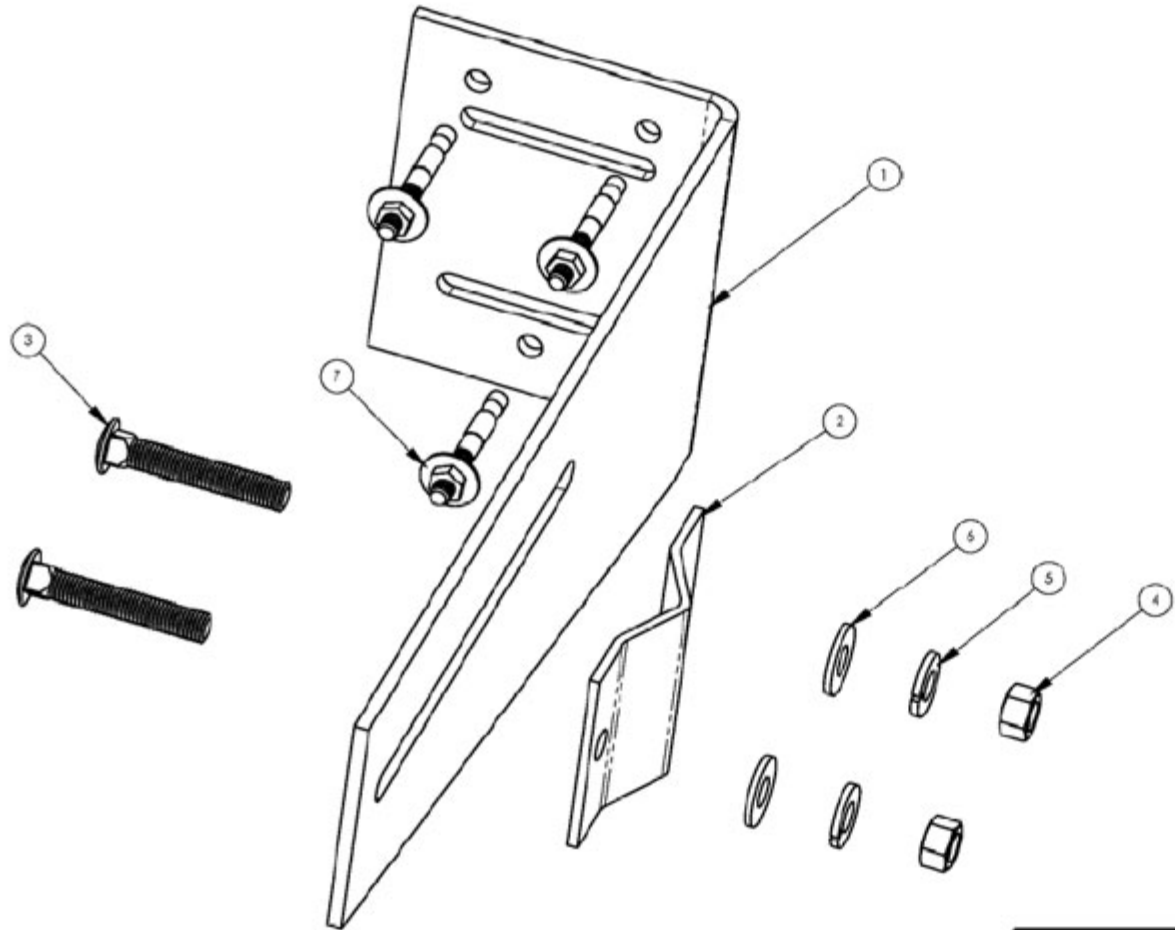

REV. NO.			
REV.	DESCRIPTION	DATE	REV. BY
A	RELEASE TO PRODUCTION PER EGN 245	9/29/99	J.D.
B	REVISED PER EGN 250	9/7/99	J.D.



Sample Drawing

NOTES: UNLESS OTHERWISE SPECIFIED

UNLESS OTHERWISE SPECIFIED DIMENSIONS ARE IN INCHES TOLERANCES ARE:		DR BY	JOSE DIAZ	DATE	6/14/99	 R.W. LYALL & COMPANY, INC. 2645 Research Dr. Corona, CA 92626
DECIMALS ANGLES ALL OTHERS		CHK BY	J DIAZ	11/1/99		
.0012 .0015 .0025 .0050 .0100 .0150 .0300 .0500 .1000 .1500 .3000 .5000		APPROV	B. KAPLAN	11/1/99		
DO NOT SCALE PRINT		PROPERTY OF R.W. LYALL & COMPANY, INC. ECN 2425				BRACKET RISER STANDOFF 14" ADJUSTABLE
MATERIAL: SEE PARTS LIST		PROPERTY RIGHT ARE INCLUDED IN THE INFORMATION DISCLOSED HEREIN. NEITHER THE DOCUMENT NOR THE INFORMATION DISCLOSED SHALL BE REPRODUCED, TRANSMITTED, OR USED IN ANY MANNER, OR DISCLOSED TO OTHERS, FOR ANY PURPOSE, INCLUDING MANUFACTURING, UNLESS SPECIFICALLY AUTHORIZED IN WRITING BY R.W. LYALL & COMPANY, INC. All rights reserved. for non-use by any other site without the property of R.W. Lyall & Company, Inc.		SIZE	PAR. NO.	REV
FINISH: EPOXY COATING PER RWL ES0801				B	BRK38-01	B
				SCALE: 1:1	CAD FILE: BRK38-01.DWG	SHEET 1 OF 1

REVISIONS			
ZONE	LTR	DESCRIPTION	DATE
A		RELEASED TO PRODUCTION PER ECN 1426	10/25/96

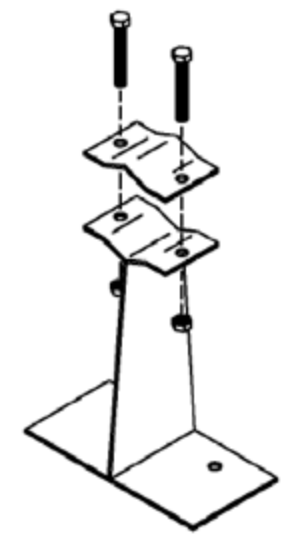
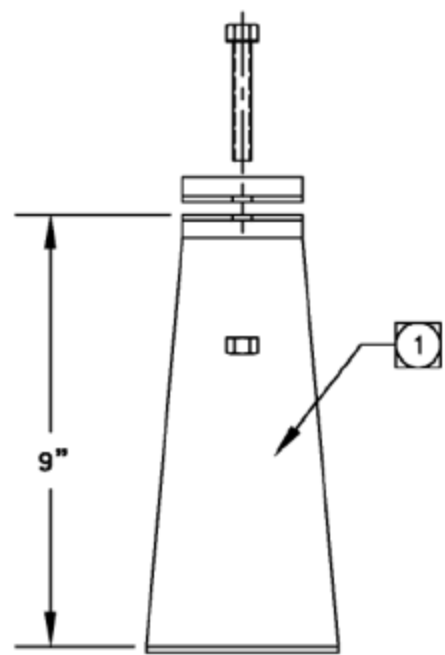
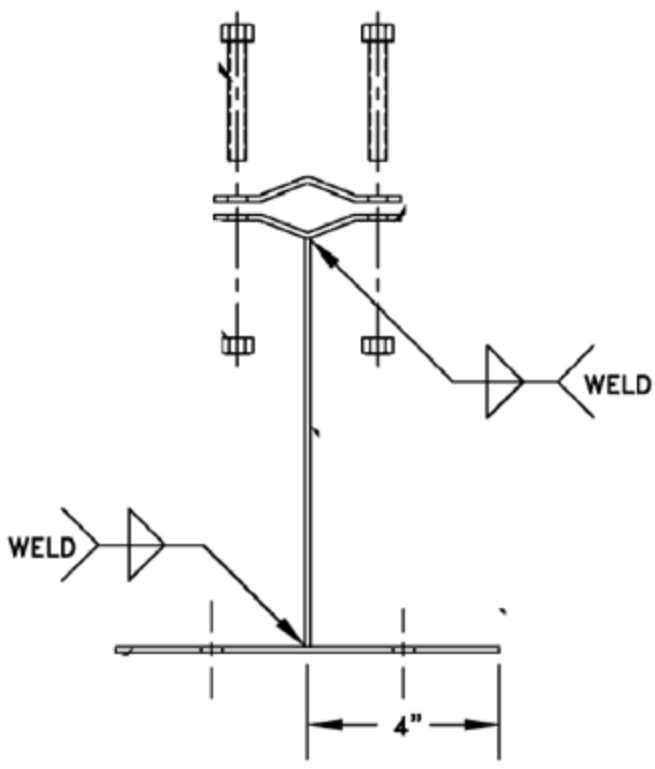
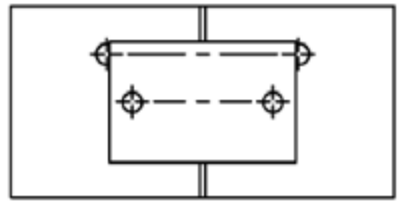

1 ASSEMBLY TO RECEIVE EPOXY COATING, GRAY 7-10 MILS DO NOT COAT NUTS & BOLTS.

NOTES: UNLESS OTHERWISE SPECIFIED.
 CAD DOCUMENT
 AUTOCAD FILE: BRKT0040

UNLESS OTHERWISE SPECIFIED DIMENSIONS ARE IN INCHES TOLERANCES ON: DECIMALS .XX = ± 1/8" .XXX = ± * ANGLES ± * DO NOT SCALE PRINT	DR BY D. HESS	DATE 8/1/96
	CHK BY P. HERNDANDEZ	DATE 10/29/96
MATERIAL: AS NOTED	APPVD L. LYALL	DATE 11/9/96
FINISH: 1	DOCUMENT RELEASE NUMBER ECN 1426	
NEXT ASSY	USED ON	APPLICATION

R.W. LYALL & COMPANY, INC. 2665 Research Dr Corona, Ca. U.S.A. Ph: (909) 270-1500 Fax: (909) 270-1600		
BRACKET, SUPPORT 9" RISER STANDOFF		
SIZE DRAWING NO. A	REV A	BRK9H
SCALE 1/4	SHEET 1 OF 1	

Sample Drawing

Sample Drawing

REVISIONS			
REV	DESCRIPTION	DATE	REV. BY
A	RELEASED TO PRODUCTION PER ECN 1886	2/5/97	A.S.
B	REVISED PER ECN 2152	7/7/98	D.P.Z.
C	REVISED PER ECN 2434	6/23/99	D.P.Z.
D	REVISED PER ECN 2790 - ADDED BRKCLAC2 TO PARTS LIST	10/9/00	D.P.Z.

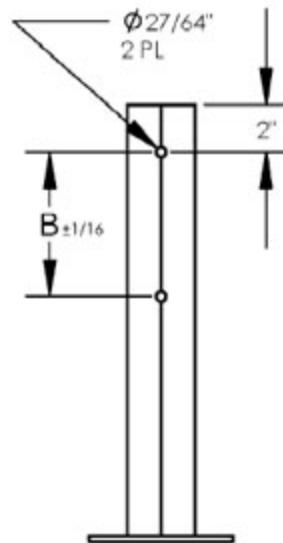
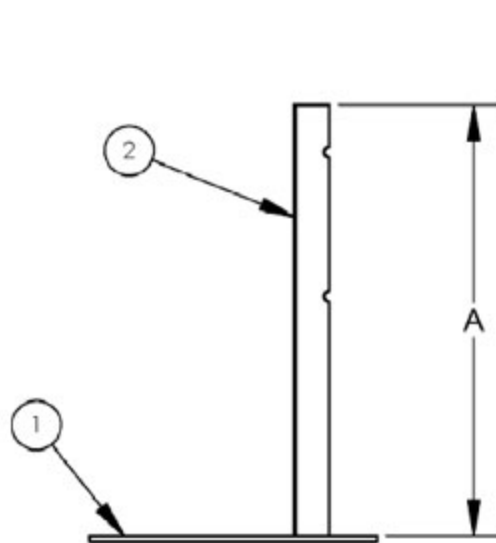
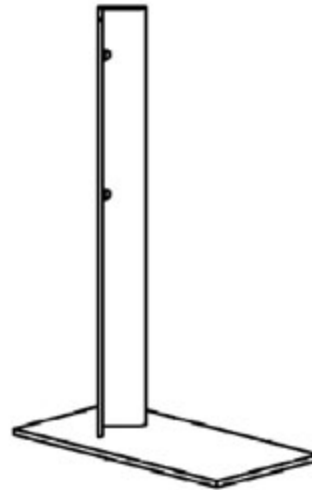
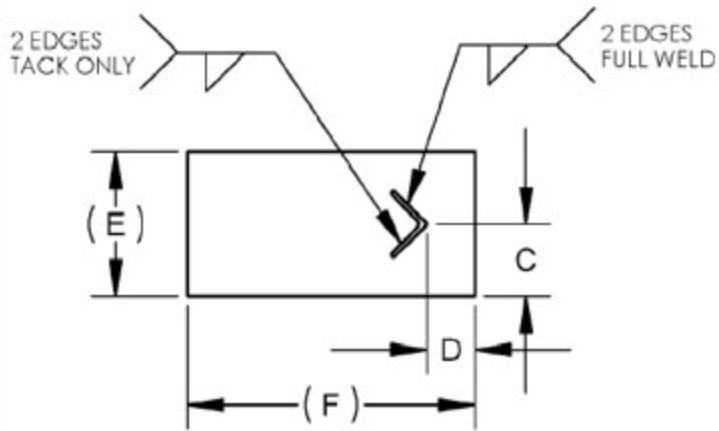

DIMENSIONS	A	21	27	33
	B	6	10	12
	C	2	2	6
	D	1	1	2½
	E	4	4	12
	F	8	8	18

PARTS LIST				
ITEM NO.	DESCRIPTION	U/M	QTY	QTY
1	PLATE STEEL 4 X 8 X 1/4	EA	1	1
	PLATE STEEL 12X18X1/4	EA		1
2	ANGLE IRON 2" X 2" X 3/16"	IN	21	27 33

UNLESS OTHERWISE SPECIFIED, DIMENSIONS ARE IN INCHES. TOLERANCES ON: DECIMALS ±.01 ANGLES ±.2° 300" ±.005 ALL OTHERS ± 1/4"	DESIGNED BY DAN ZAPALAC DATE 7/7/98	DATE 10/9/00	R.W. LYALL & COMPANY, INC. 2665 Research Dr Cotona, Ca. U.S.A. Ph: (909) 270-1500 Fax: (909) 270-1600
DO NOT SCALE PRINT	APPVD D. ZAPALAC DATE 10/9/00	DOCUMENT RELEASE NUMBER ECN 1886	
MATERIAL: SEE PARTS LIST	Proprietary rights are included in the information disclosed herein. Neither this document nor any information disclosed shall be reproduced, used, transferred to other documents, or disclosed to others for any purpose, including manufacturing unless specifically authorized in writing by R.W. Lyall & Company, Inc. Also all rights for manufacturing and/or sale remain the property of R.W. Lyall & Company, Inc.		RISER SUPPORT STAND WITH SUPPORT PLATE AND 2" ANGLE IRON
FINISH: EPOXY COATING PER RWL SPEC ES0801	SIZE A	DRAWING NO. BRKSTND	REV D
SCALE: 1:8		CAD FILE: BRKSTND.SLDRW	SHEET 1 OF 1

NOTES: UNLESS OTHERWISE SPECIFIED.

4

3

2

1

REVISIONS				
ZONE	LTR	DESCRIPTION	DATE	REV. BY
	A	RELEASED TO PRODUCTION PER ECN 1843	11/3/97	A.S.
	B	REVISED PER ECN 2484	8/11/99	W.R.M.
	C	REVISED PER ECN 2555	11/2/99	W.R.M.

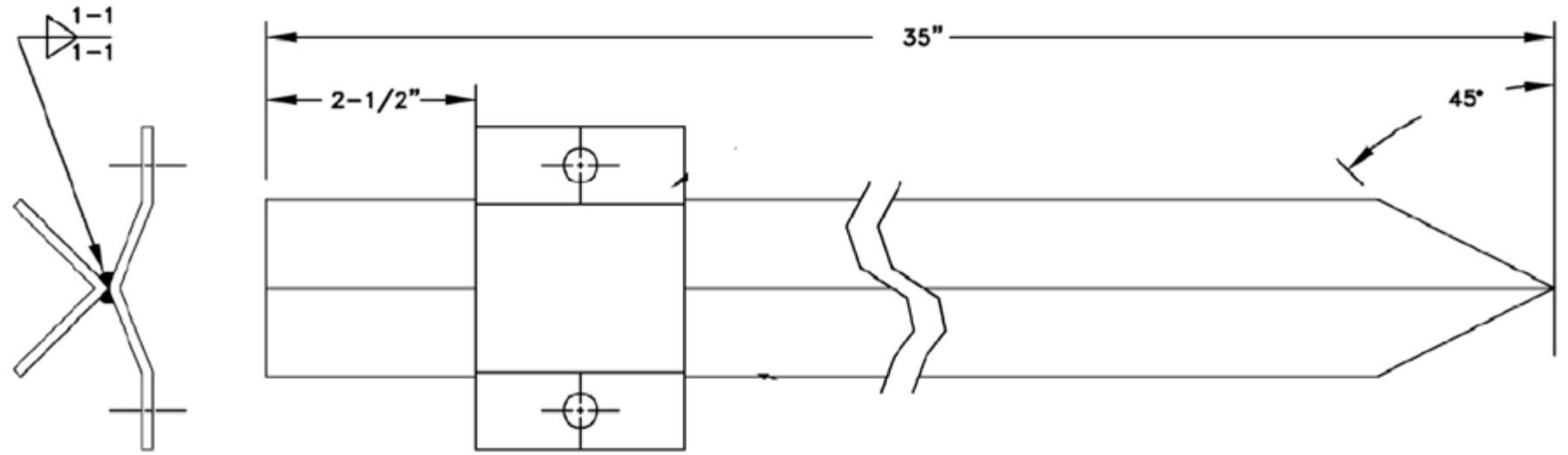
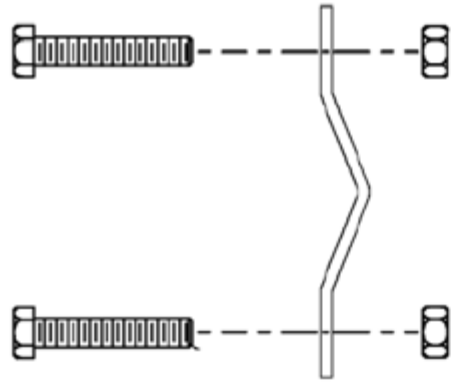

- ② EPOXY COAT 5 MIL MIN
- 1) SUPPORT PLATE ASSEMBLED TO POST.

NOTES: UNLESS OTHERWISE SPECIFIED.

CAD DOCUMENT
AUTOCAD FILE: BRKT0056

N/A	N/A	UNLESS OTHERWISE SPECIFIED DIMENSIONS ARE IN INCHES TOLERANCES ON:	DR BY A. SHARMA	DATE 11/3/97
		DECIMALS .XX = ± .12 .XXX = ± .005	CHK BY W. MCCRAY	DATE 11/2/99
NEXT ASSY		USED ON	APPVD B. KAPLAN	DATE 11/2/99
APPLICATION		FINISH: ②	DOCUMENT RELEASE NUMBER ECN 1843	
			<small>Proprietary rights are included in the information disclosed herein. Neither this document nor any information disclosed shall be reproduced, used, transferred to other documents, or disclosed to others for any purpose, including manufacturing unless specifically authorized in writing by R.W. Lyall & Company, Inc. Also all rights for manufacturing and/or sale remain the property of R.W. Lyall & Company, Inc.</small>	

R.W. LYALL & COMPANY, INC.
2665 Research Dr Corona, Ca. U.S.A.
Ph: (909) 270-1500 Fax: (909) 270-1600

BRACKET,
1-1/2 x 1-1/2
36 SPT PST

SCALE 1:1 SHEET 1 OF 1
DRAWING NO. -BRK56

4

3

2

1

REV.	BMR NO.	APP.	DATE
A	1078	<i>[Signature]</i>	9/13/85

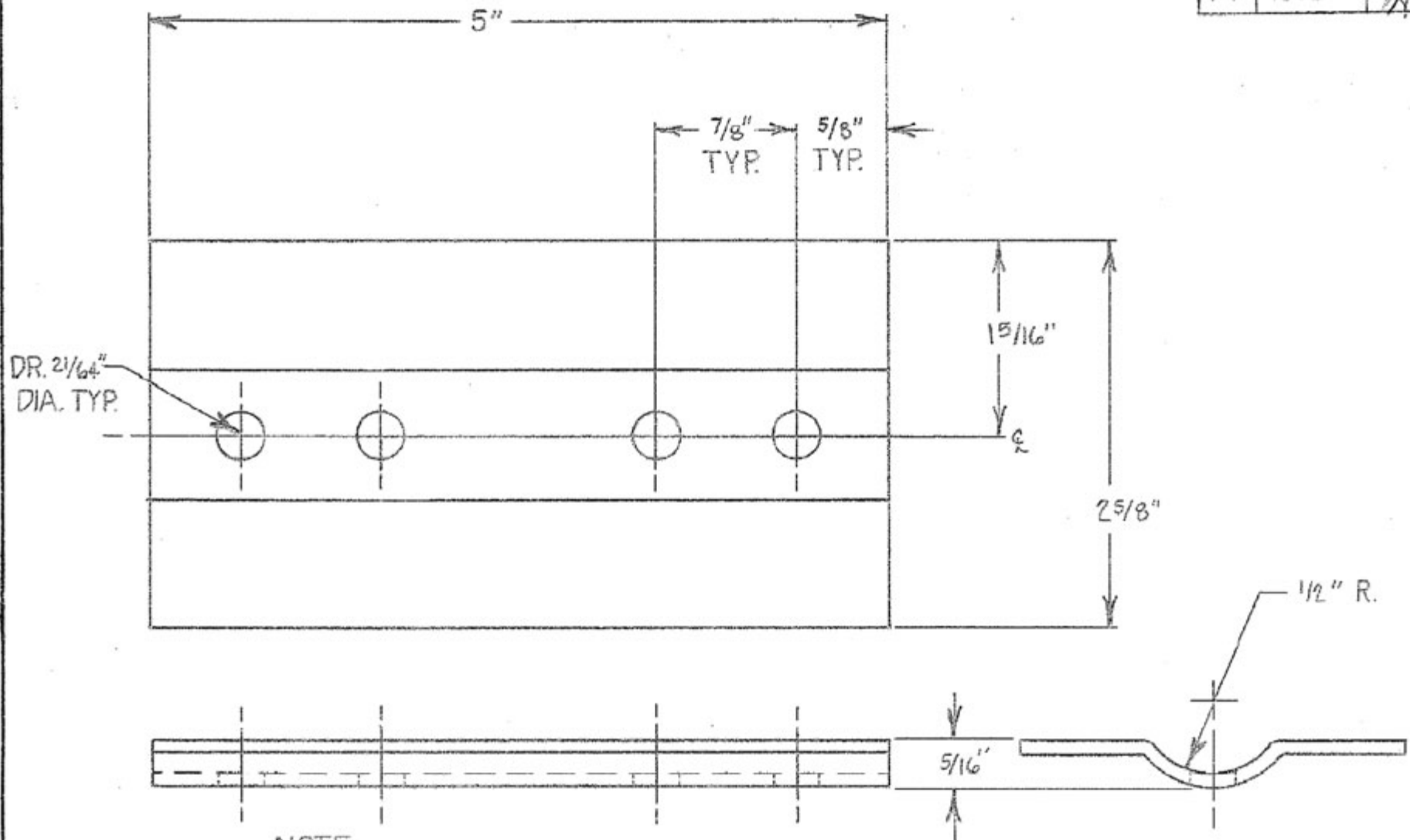

NOTE:
1.) PAINTED GREY AFTER BENDING

PART NUMBER: BRK20RBOTTOM

TOLERANCES: UNLESS SPECIFIED .XXX ——— $\pm \frac{1}{2}^\circ$ $\frac{x}{y} \pm \frac{1}{64}^\circ$ \odot ——— SURFACE FINISH 125	USE: FOR 1 1/4" IPS METER RISER BRACKET	R. W. LYALL CO. INC. Sample Drawing	
	MATERIAL: 12 GAGE STEEL PLATE	SCALE: FULL DRN: PDR 5-10 APP: <i>[Signature]</i>	TITLE: 20 BRACKET

REV.	BMR NO.	APP.	DATE
A	1078		11/13/85

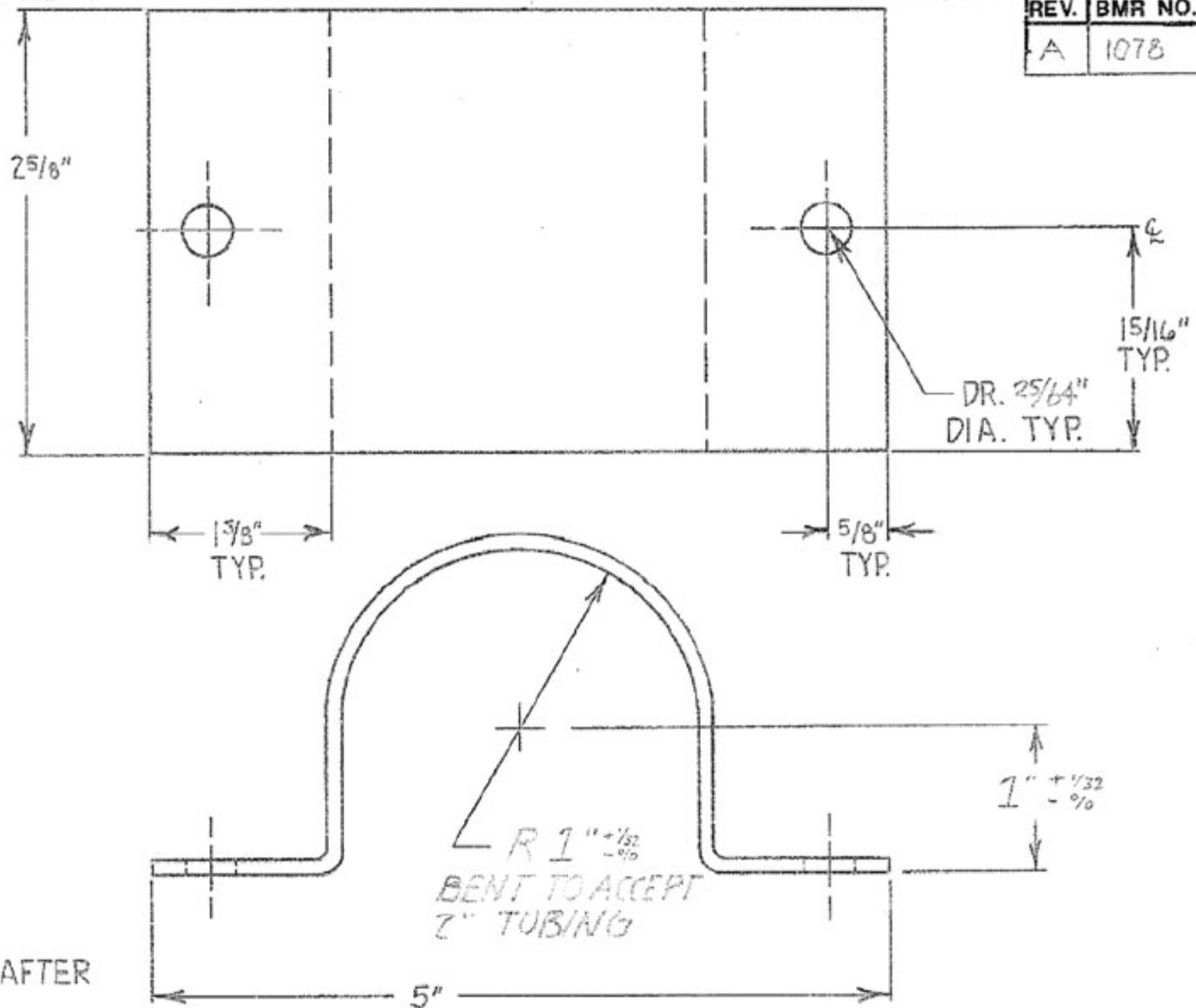

NOTE:
1.) PAINTED GREY AFTER BENDING.

PART NUMBER: BRK20RTOP

TOLERANCES: UNLESS SPECIFIED .XXX ——— $\pm \frac{1}{2}^\circ$ $\frac{x}{y}$: $\pm \frac{1}{64}''$ \odot : ——— SURFACE FINISH 125	USE: FOR 1/4" IPS METER RISER BRACKET	R. W. LYALL CO. INC. Sample Drawing	
	MATERIAL: 12 GAGE STEEL PLATE	SCALE: NONE DRN: PDR 5- APP: <i>[Signature]</i>	TITLE: 20 BRACKET

REVISIONS				
REV	ECN	DESCRIPTION	DATE	REV. BY
A	2765	REDRAWN IN SOLIDWORKS	9/11/00	D.P.Z.
B	3808	ADDED BREAKOUTS OF SUB-ASSEMBLY PIECES	11/30/04	D.P.Z.

Sample Drawing

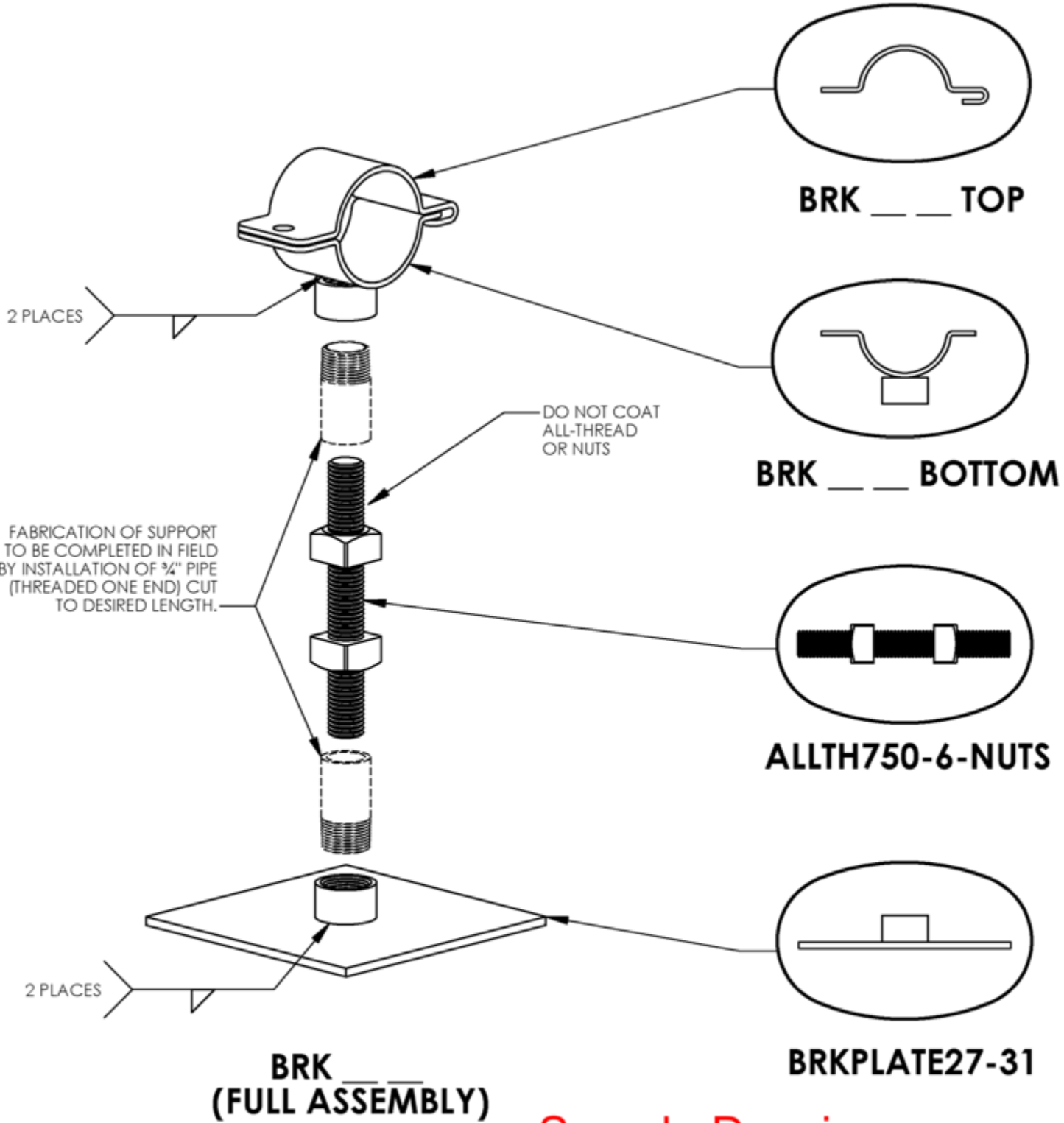

Sample Drawing

UNLESS OTHERWISE SPECIFIED DIMENSIONS ARE IN INCHES TOLERANCES ON: DECIMALS .000 ± .01 ANGLES ± 2° ALL OTHERS ± 1/8" .0000 ± .005 DO NOT SCALE PRINT MATERIAL: SEE PARTS LIST FINISH: POLYESTER COATING PER RWL SPEC ES0802	DR BY DAN ZAPALAC DATE 9/11/00	R.W. LYALL & COMPANY, INC. 2665 Research Dr Corona, Ca. U.S.A. Ph: (951) 270-1500 Fax: (951) 270-1600
	CHK BY C. RAVEN DATE 11/30/04	
	APPVD D. ZAPALAC DATE 11/30/04	
DOCUMENT RELEASE NUMBER ECN 2765		LOCKABLE METER MANIFOLD SUPPORT 3/4", 1", 1 1/4", 1 1/2", & 2"
PROPRIETARY RIGHTS ARE INCLUDED IN THE INFORMATION DISCLOSED HEREIN. NEITHER THIS DOCUMENT NOR ANY INFORMATION DISCLOSED SHALL BE REPRODUCED, USED, TRANSFERRED TO OTHER DOCUMENTS, OR DISCLOSED TO OTHERS FOR ANY PURPOSE, INCLUDING MANUFACTURING UNLESS SPECIFICALLY AUTHORIZED IN WRITING BY R.W. LYALL & COMPANY, INC. ALSO ALL RIGHTS FOR MANUFACTURING AND/OR SALE REMAIN THE PROPERTY OF R.W. LYALL & COMPANY, INC.		
SIZE A		DRAWING NO. BRK27-31
SCALE: 1:1		CAD FILE: BRK27-31.SLDDRW
SHEET 1 OF 1		REV B

NOTES:
UNLESS OTHERWISE SPECIFIED