

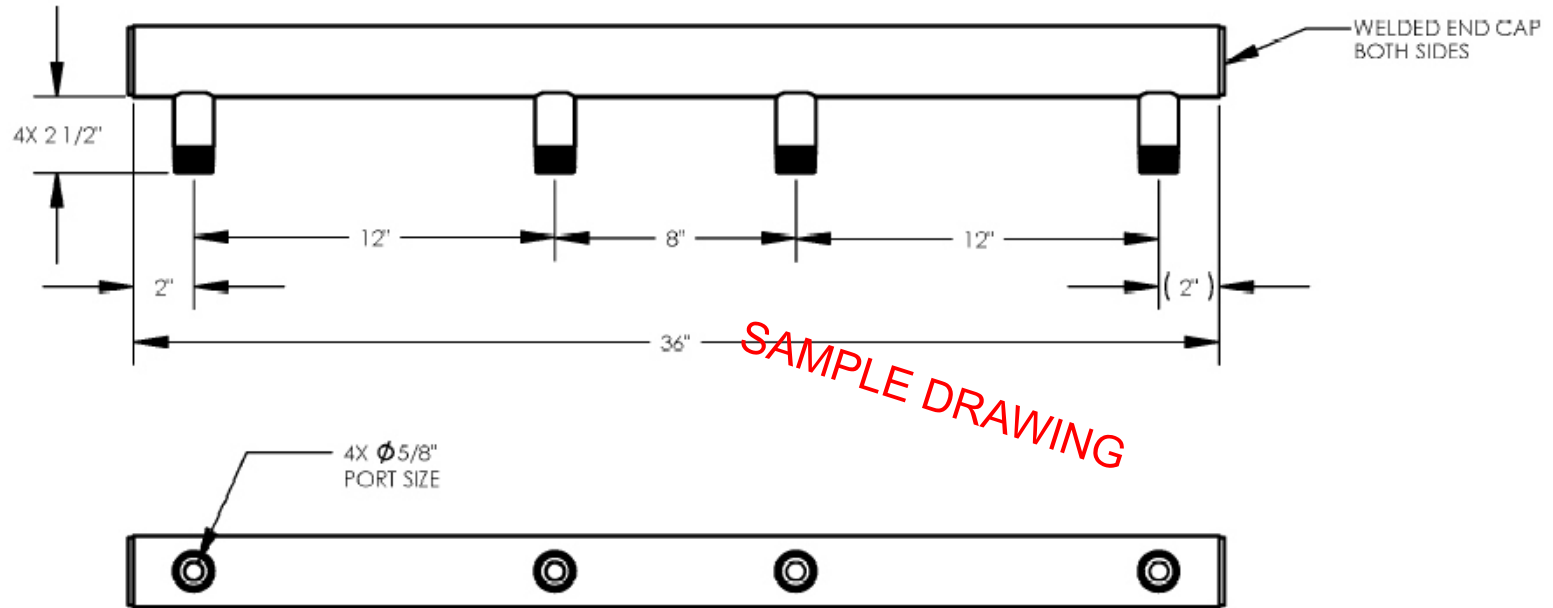

REVISIONS				
REV	ECN	DESCRIPTION	DATE	REV. BY
A	3030	RELEASED TO PRODUCTION	11/6/01	J.D.



NOTES: UNLESS OTHERWISE SPECIFIED.

UNLESS OTHERWISE SPECIFIED DIMENSIONS ARE IN INCHES TOLERANCES ON: DECIMALS ANGLES ALL OTHERS 300± .01 ± 2° ± 1/8" 300± .005	DR BY	JOSE DIAZ	DATE	10/26/01	 R.W. LYALL & COMPANY, INC. 2665 Research Dr Ph: (909) 270-1500 Corona, Ca. U.S.A. Fax: (909) 270-1600
	CHK BY	C. ZAPALAC	DATE	11/6/01	
DO NOT SCALE PRINT	APPVD	R. McCLURE	DATE	11/6/01	METER MANIFOLD NPS 2 HEADER X NPS 1 (4) OUTLETS
MATERIAL: SEE PARTS LIST	DOCUMENT RELEASE NUMBER		ECN 3030		
FINISH: POLYESTER COATING PER RWL SPEC ES0802	Proprietary rights are included in the information disclosed herein. Neither this document nor any information disclosed shall be reproduced, used, transferred to other documents or disclosed to others for any purpose, including manufacturing, unless specifically authorized in writing by R.W. Lyall & Company, Inc. All rights for manufacturing and/or sale remain the property of: R.W. Lyall & Company, Inc.		SIZE	DRAWING NO.	REV
			A	SAMPLE DRAWING	A
SCALE: 1:6			CAD FILE: MMEB36CC4-001.SLDDRW	SHEET 1 OF 1	

REVISIONS				
REV	ECN	DESCRIPTION	DATE	REV. BY
A	2934	RELEASED TO PRODUCTION	6/1/01	J.D.

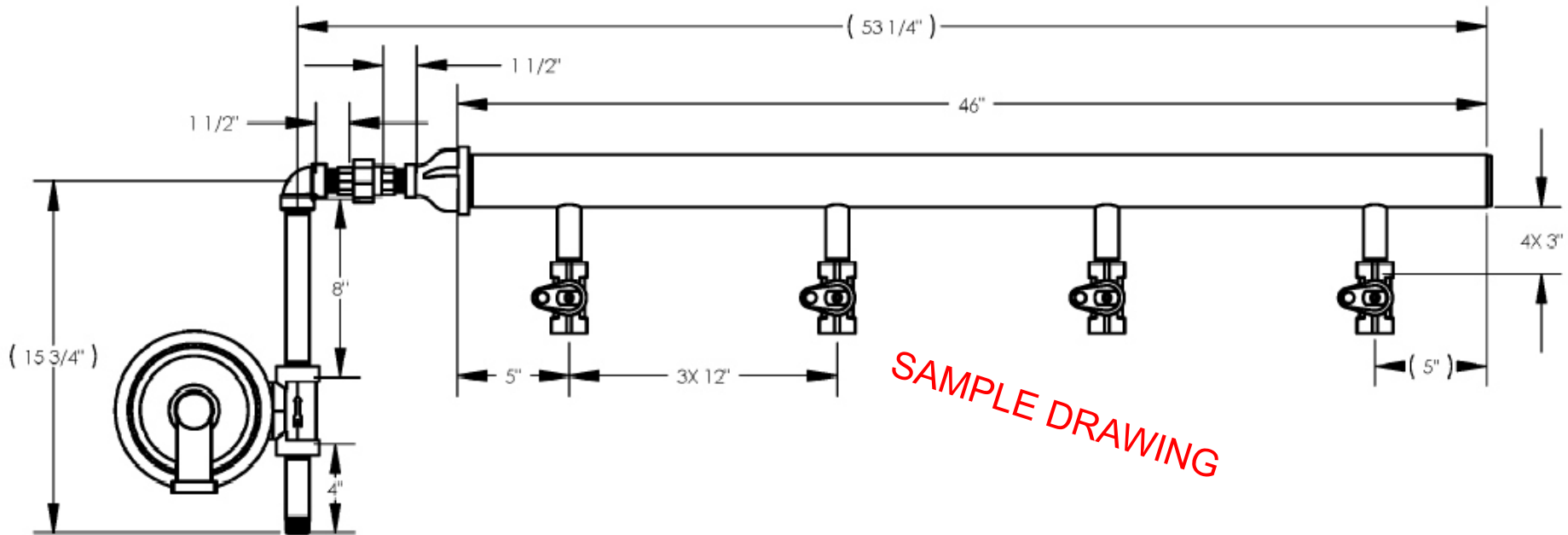

SAMPLE DRAWING

1. VALVE ORIENTATION: AS SHOWN
STEM POSITION: AS RECEIVED
PIPE DOPE TYPE: REF RWL ES0905
TORQUE: PER RWL ES0905
COATING: NONE
PLUG: STANDARD DUST CAP
2. ASSEMBLE ALL THREADED COMPONENTS AND TORQUE PER RWL SPECIFICATION ES 0905.
3. PRESSURE TEST ASSEMBLY FOR A MINIMUM OF 15 SECONDS AT 100 PSIG.
4. DIMENSIONS IN PARENTHESES ARE FOR REFERENCE ONLY.

NOTES: UNLESS OTHERWISE SPECIFIED.

UNLESS OTHERWISE SPECIFIED DIMENSIONS ARE IN INCHES TOLERANCES ON:			DR BY	CHRIS ZAPALAC	DATE	4/4/01	R. W. LYALL & COMPANY, INC. 2665 Research Dr Corona, Ca. U.S.A. Ph: (909) 270-1500 Fax: (909) 270-1600
DECIMALS	ANGLES	ALL OTHERS	CHK BY	G. ZAPALAC	DATE	6/6/01	
.XXX ± .01	± 2°	± 1/16"	APPVD	D. ZAPALAC	DATE	6/6/01	
.XXX ± .005			DOCUMENT RELEASE NUMBER ECN 2934				
DO NOT SCALE PRINT			MATERIAL: SEE PARTS LIST				
FINISH: POLYESTER COATING PER RWL SPEC ES0802			Proprietary rights are included in the information disclosed herein. Neither this document nor any information disclosed shall be reproduced, used, transferred to other documents or disclosed to others for any purpose, including manufacturing unless specifically authorized in writing by R.W. Lyall & Company, Inc. Also all rights for manufacturing and/or sale remain the property of R.W. Lyall & Company, Inc.				
SIZE	DRAWING NO.				REV		
A	SAMPLE DRAWING				A		
SCALE: 1:7		CAD FILE: MMA-PACPP-02.SLDRW			SHEET 1 OF 1		

REVISIONS				
REV	ECN	DESCRIPTION	DATE	REV. BY
A	3677	RELEASED TO PRODUCTION	5/12/04	J.D.

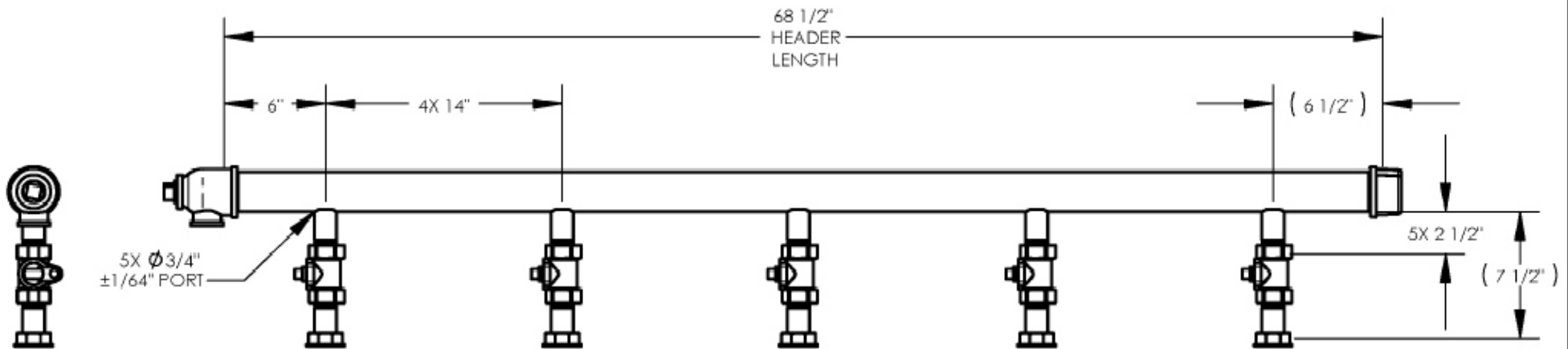

SAMPLE DRAWING

VALVE INFORMATION
 STEM POSITION: AS RECEIVED
 COATING: GRAY PAINT
 PIPE DOPE: PER RWL ES0905
 TORQUE: PER RWL ES0905

SQAURE HEAD PLUG:
 PIPE DOPE: PER RWL ES0905
 TORQUE: PER RWL ES0905

1. LEAK TEST: ALL GAS CARRYING WELDS AND THREAD JOINTS LEAK TESTED AT 90 PSIG FOR A MINIMUM OF 15 SECONDS.
2. DIMENSIONS IN PARENTHESES ARE FOR REFERENCE ONLY.

NOTES: UNLESS OTHERWISE SPECIFIED.

UNLESS OTHERWISE SPECIFIED DIMENSIONS ARE IN INCHES TOLERANCES ON:			R.W. LYALL & COMPANY, INC. 2665 Research Dr Corona, Ca, U.S.A.	
DECIMALS XX±.01 XXXX±.005	ANGLES ±2°	ALL OTHERS ± 1/8"	DR BY JOSE DIAZ	DATE 5/5/04
DO NOT SCALE PRINT			CHK BY G. RAVEN	DATE 5/13/04
			APPVD D. ZAPALAC	DATE 5/13/04
MATERIAL: SEE BILL OF MANUFACTURE			PROPRIETARY RIGHTS ARE INCLUDED IN THE INFORMATION DISCLOSED HEREIN. NEITHER THIS DOCUMENT NOR ANY INFORMATION DISCLOSED SHALL BE REPRODUCED, USED, TRANSFERRED TO OTHER DOCUMENTS, OR DISCLOSED TO OTHERS FOR ANY PURPOSE, INCLUDING MANUFACTURING UNLESS SPECIFICALLY AUTHORIZED IN WRITING BY R.W. LYALL & COMPANY, INC. ALSO ALL RIGHTS FOR MANUFACTURING AND/OR SALE REMAIN THE PROPERTY OF R.W. LYALL & COMPANY, INC.	
FINISH: POLYESTER COATING PER RWL SPEC ES0802			DOCUMENT RELEASE NUMBER ECN 3677	
METER MANIFOLD ASSEMBLY NPS 2 HEADER X 1" PITTSBURGH SWIVELS			SIZE A	DRAWING NO. SAMPLE DRAWING
			SCALE: 1:1 CAD FILE: MMA-ENSTR-04.SLDDRW SHEET 1 OF 1	