

# LYALL GAS PIPING PRODUCTS

## Support Brackets & Stakes

### Brackets for Risers & Manifolds

Bracket/Stake Type	Product Support	Part Number
Wall Bracket 9"	Riser	BRK9H
Wall Bracket Adjustable 14"	Riser	BRK38-01
Concrete Pad Adjustable Bracket	¾" Manifold	BRK27-31

Note: Many other bracket styles and sizes are available; please contact your Lyall representative for more information.

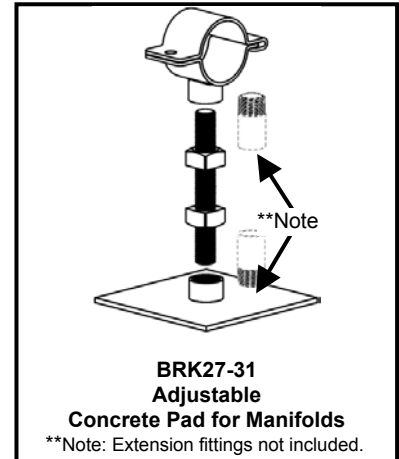
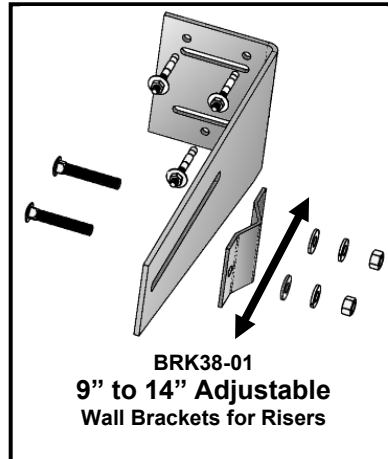
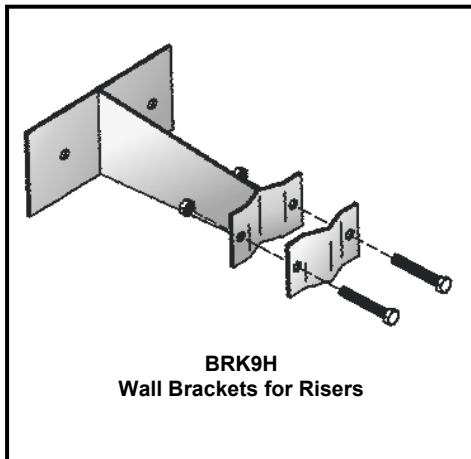

### Support Stakes for Risers & MSA's

Stake Type	Length (H)	Holes (B)	Product Support	Part Number
Support Stake	48"	N/A	MSA	BRK01-001
Support Stake/Stand	33"	12"	Riser	BRKLAC2
Support Stake	35"	N/A	Riser	KPLGS36-BRK36

Note: Many other support stake styles and sizes are available; please contact your Lyall representative for more information.

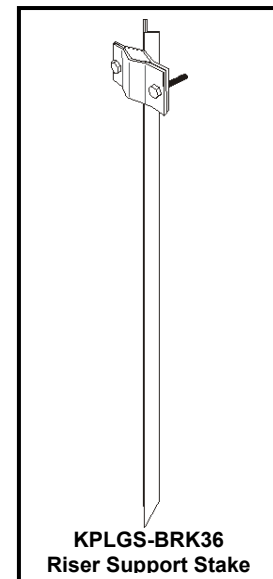
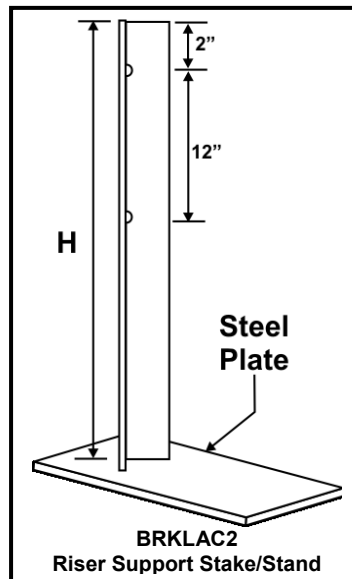
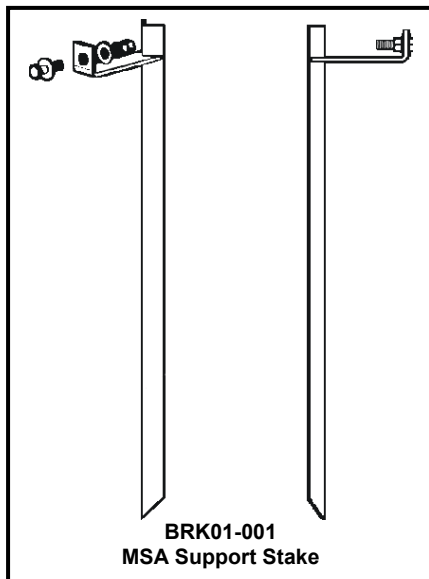

**CUSTOMER SERVICE: (800) 535-9255 • Web site: [www.rwlyall.com](http://www.rwlyall.com)**

The products listed on this page only represent the most commonly used sizes and configurations. Please contact your local Lyall representative or a Lyall Customer Service representative for additional sizes, customized configurations and available options.